

6

5

4

3

2

1

REVISIONS

ZONE	REV.	DESCRIPTION	DATE	APPROVED

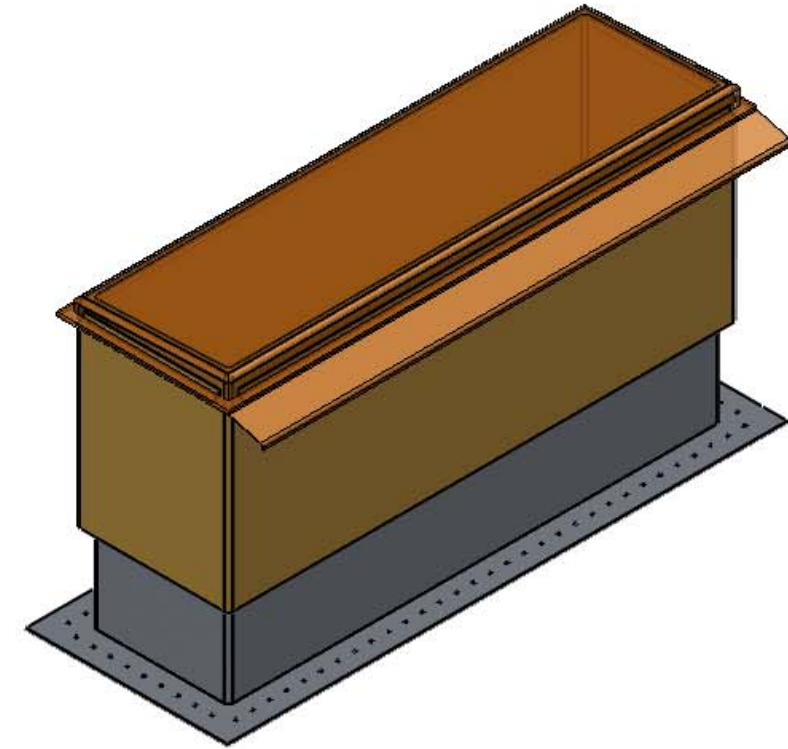
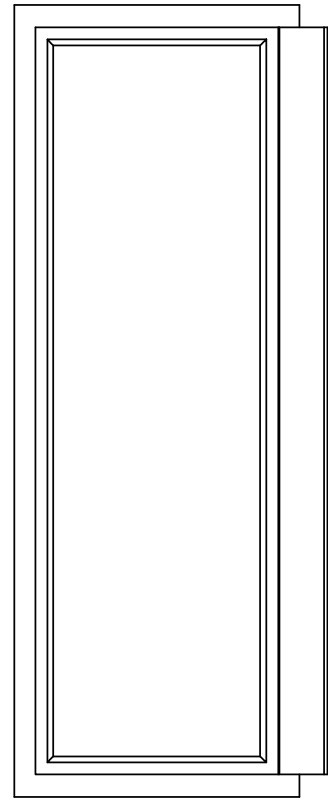

P/N: DH-186024  
 DESCRIPTION: DATA CENTER PIPE CHASE HOUSING & CURB

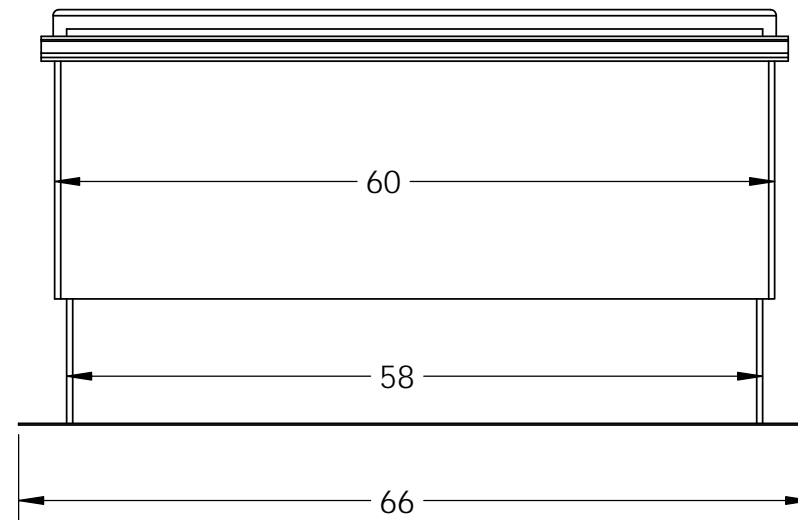
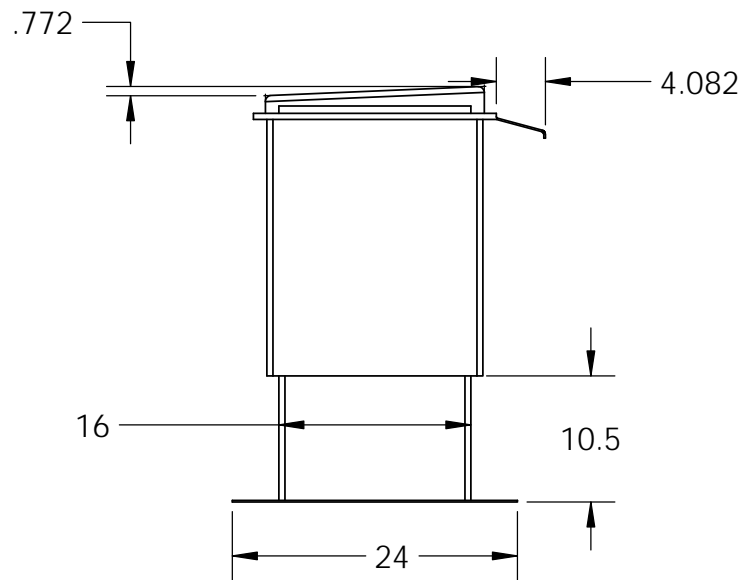

<b>PROPRIETARY AND CONFIDENTIAL</b> THE INFORMATION CONTAINED IN THIS DRAWING IS THE SOLE PROPERTY OF ALTA PRODUCTS, LLC. ANY REPRODUCTION IN PART OR AS A WHOLE WITHOUT THE WRITTEN PERMISSION OF ALTA PRODUCTS, LLC IS PROHIBITED.	NAME	DATE	PROJECT: PIPE CHASE HOUSING
	DRAWN		DESCRIPTION: <b>DATA CENTER PIPE CHASE HOUSING &amp; CURB</b>
	CHECKED		
	APPROVED		
UNLESS OTHERWISE SPECIFIED <small>ALL DIMENSIONS ARE IN INCHES          INTERPRET DRAWINGS PER ASME 14.5-2009</small>			SIZE <b>B</b>
$\angle$ $\pm 1^\circ$	.X $\pm .1$	.XX $\pm .03$	.XXX $\pm .005$
THIRD ANGLE PROJECTION			DWG NO. _____ REV. _____
SCALE NONE			WEIGHT: _____ SHEET 1 OF 1

6

5

4

3

2

1

E

D

C

B

A

E

D

C

B

A